

Badger[®] Universal Control Head



P/N: 60-120099-002

Effective: August 2013
B-87-027

FEATURES

- *For Use in:*
 - *Range Guard[®] Commercial Cooking Fire Suppression Systems*
 - *Industry Guard[™] Industrial Fire Suppression Systems*
- *Pneumatic Release of up to 20 Agent Cylinders*
- *Two Discrete Mechanical Detection Lines*
- *Cylinder or Wall Mount*
- *Up to 400 ft. Mechanical Detection Cable*
- *Operates 2 Gas Valves*
- *Available 24 V Electrical Actuation*
- *Multiple Remote Release Options*
- *Rugged, Die-Cast Aluminum Body*
- *Tamper/Lock Port for Cover*
- *Easy to Install and Maintain*
- *UL & ULC Listed*
- *FM Approved for Industry Guard Systems*

DESCRIPTION

The Badger Universal Control Head is a compact, versatile unit used to actuate agent cylinders on Badger Range Guard and Industry Guard Pre-Engineered fire suppression systems. The control head can be operated via:

- Two Distinct Automatic Mechanical Detection Lines (fusible links or thermo-bulb links)
- Optional Electrical Solenoid
- Remote or Local Manual Mechanical Control

Upon actuation, the Universal Control Head discharges the nitrogen System Cartridge, pressurizing the actuation lines and System Valve Actuators (SVA) mounted on the cylinder valve(s). The SVA(s) open the cylinder valve(s),

discharging the Range Guard wet chemical or Industry Guard dry chemical suppression agent. The UCH can be mounted on a wall or directly to an SVA mounted on the cylinder.

The Universal Control Head is UL and ULC Listed with Range Guard Wet Chemical and Industry Guard Dry Chemical Fire Suppression Systems. The UCH is FM approved with the Industry Guard Dry Chemical Systems.

The UCH comes ready to install, with three EMT connectors, one System Valve Actuator (SVA), two microswitches, one nitrogen System Cartridge, and one nitrogen test cartridge.



Figure 1. UCH Control System, P/N 60-120099-002

TECHNICAL DATA

Table 1. Mechanical Cable Parameters for Range Guard & Industry Guard Systems

UCH Cable Line	Max. Cable Length	Max. Corner Pulleys	Max. Detectors	Max. Tee Pulleys
Detection and Manual Release-to-Trip Line 1	200 ft. (60.96 m)	50	40	*
Detection and Manual Release-to-Trip Line 2	200 ft. (60.96 m)	50	40	*
Pull-to-Trip Remote Manual Release Line	100 ft. (30.48 m)	30	-	1*
Mechanical Gas Valve Line	100 ft. (30.48 m)	30	-	1*

*Tee pulleys count as two Corner Pulleys. Maximum is from Universal Control Head, through the pulley, to each device.

Table 2. Actuation Parameters for Range Guard Wet Chemical Systems

Operating Temperature Range	Number of Extinguishing System Cylinders	Maximum Total Length Copper Actuation Tubing	Minimum Total Length of Copper Actuation Tubing
0°F to 120°F (-18°C to 49°C)	1-12	106 ft. (32.30 m)	5 ft. (1.52 m)
	13-20	91 ft. (27.73 m)	

Table 3. Actuation Parameters for Industry Guard Industrial Dry Chemical and Open-Face Spray Booth Systems

Operating Temperature Range	Number of Extinguishing System Cylinders	Maximum Total Length Copper Actuation Tubing	Minimum Total Length of Copper Actuation Tubing
-40°F to 120°F (-40°C to 49°C)	1-14	166 ft. (50.60 m)	5 ft. (1.52 m)
	15-20	121 ft. (36.88 m)	

Table 4. Actuation Parameters for Industry Guard Dry Chemical for Vehicle Spray Booths

Operating Temperature Range	Number of Extinguishing System Cylinders	Maximum Total Length Copper Actuation Tubing	Minimum Total Length of Copper Actuation Tubing
0°F to 120°F (-18°C to 49°C)	1-8	200 ft. (60.96 m)	5 ft. (1.52 m)
	9-15	160 ft. (48.76 m)	
	16-20	140 ft. (42.67 m)	

NOTES

1. Braided high pressure nitrogen tubing (P/N 87-120045-00X), is required to connect the Universal Control Head to the System Valve Actuator (SVA) when the Universal Control Head is cylinder mounted.
2. Copper tubing shall be 1/4-inch O.D. x 0.031-inch wall high pressure tubing.
3. When Control System is cylinder mounted and two or more cylinders are being actuated, a minimum of 5 ft. (1.52 m) of 1/4-inch O.D. x 0.031-inch wall tubing shall be used for actuation lines.

4. When Control System is wall mounted, a minimum of 5 ft. (1.52 m) of 1/4-inch O.D. x 0.031-inch wall tubing shall be used in the overall actuation line.
5. High pressure nitrogen tubing (P/N 87-120045-00X) may be used in place of copper tubing, not to exceed a maximum length of 30 feet (9 m).
6. In every system, either single cylinder or multiple cylinder, a 1/8-inch NPT plug or vent check (P/N WK-877810-000) shall be used in the outlet port of the last System Valve Actuator(s) in the actuation line.
7. A maximum of 2 Pressure Switches (P/N 486536) may be used in the actuation line.

SYSTEM NITROGEN CARTRIDGE, P/N 87-120043-001

The Universal Control Head uses a nitrogen cartridge for actuating the system cylinders and is charged with dry nitrogen (see Figure 2). The cartridge is mounted inside the Universal Control Head to protect it from tampering and provides the date of manufacturing and space (gray band) for recording the installation date.

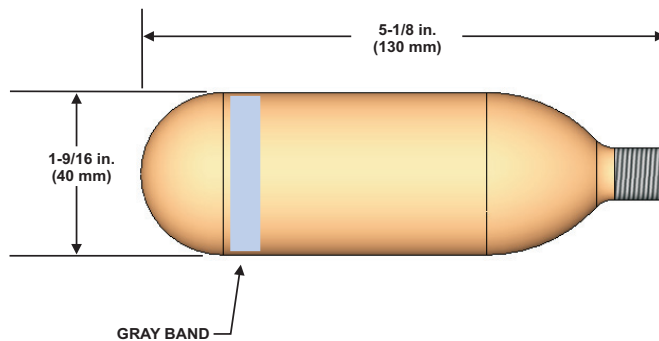

Figure 2. System Nitrogen Cartridge, P/N 87-120043-001

TEST CARTRIDGE, P/N 87-120044-001

The Test Cartridge is used for functional testing of the Badger Range Guard Wet Chemical System and Industry Guard Dry Chemical System*. The cartridge has a red band and is labeled "TEST CARTRIDGE" as shown in Figure 3.

***Note:** The System Nitrogen Cartridge P/N 87-120043-001 is required for actuation and full discharge or "puff" tests, and when a time delay is included (as in systems protecting Vehicle Spray Booths).

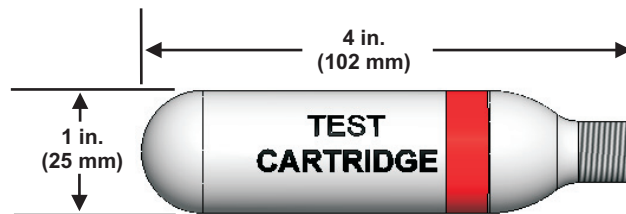

Figure 3. Test Cartridge, P/N 87-120044-001

SYSTEM VALVE ACTUATOR (SVA), P/N 87-120042-001

A System Valve Actuator (SVA) must be mounted to every system cylinder valve assembly (see Figure 4). The SVA has ports for low profile tubing runs, and is also equipped with a spring loaded plunger that locks the piston in the discharged position, ensuring complete discharge of the cylinder(s) contents.

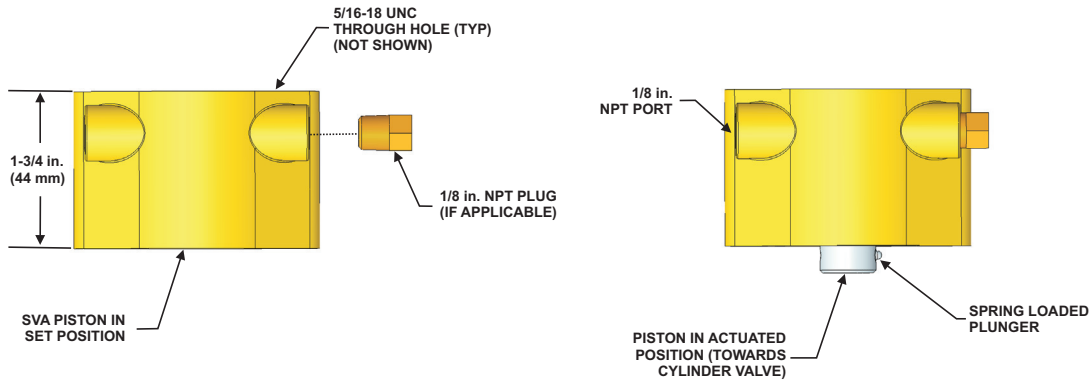

Figure 4. System Valve Actuator (SVA), P/N 87-120042-001

HIGH-PRESSURE NITROGEN TUBING, P/N 87-120045-00X

The High-Pressure Nitrogen Tubing is used to connect the Universal Control Head to the SVA on all installations in which the Universal Control Head is mounted to a wet or dry chemical cylinder. (see Figure 5). A 1/8-inch NPT (male) x 3/8-24 JIC Adapter is included with the High Pressure Nitrogen Tubing.

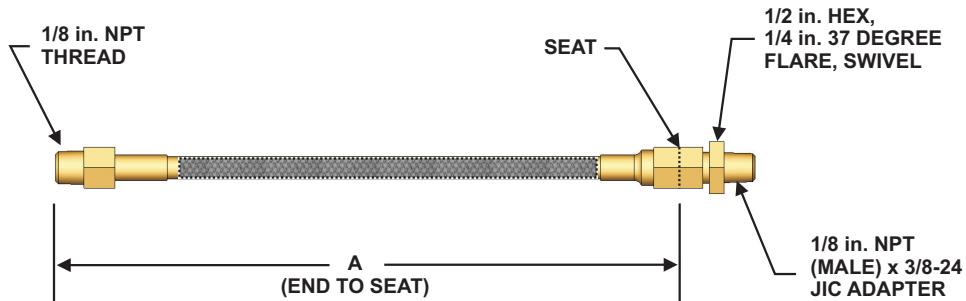

Figure 5. External Tubing for Universal Control Head, P/N 87-120045-00X

Table 5. External Tubing for Universal Control Head

Part Number	Length "A"
87-120045-001	7-1/2 in. (191 mm)
87-120045-002	24 in. (610 mm)
87-120045-003	60 in. (1524 mm)

SOLENOID, P/N 83-100034-001

An optional solenoid can be installed into the Universal Control Head, just under the actuation latch. The solenoid operates directly on the actuation latch to activate the system. This installation allows simultaneous usage of mechanical detection lines, or the lines can be locked out. The solenoid includes two mounting bolts, the bracket and a push plate which mounts onto the solenoid body (Figure 6). The solenoid coil is 24 Vdc at 1.5 Amp and at 70°F (21°C). Refer to Figure 7 for Release Wiring with Terminal Type Microswitch.

When actuating the Universal Control Head with an optional solenoid, a UL Compatible and Listed fire control panel with a supervised power supply is required, such as the Kidde AEGIS™ or Kidde ARIES™.

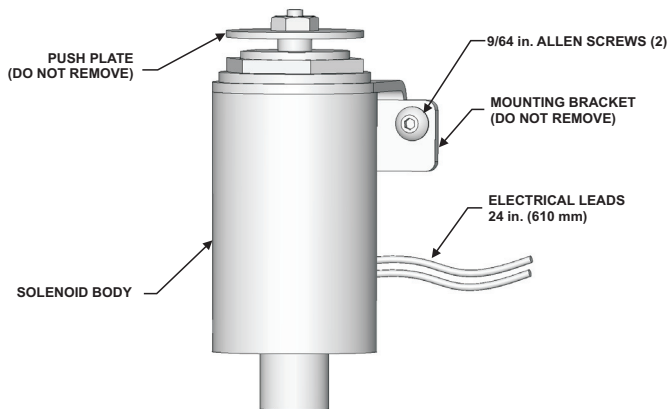
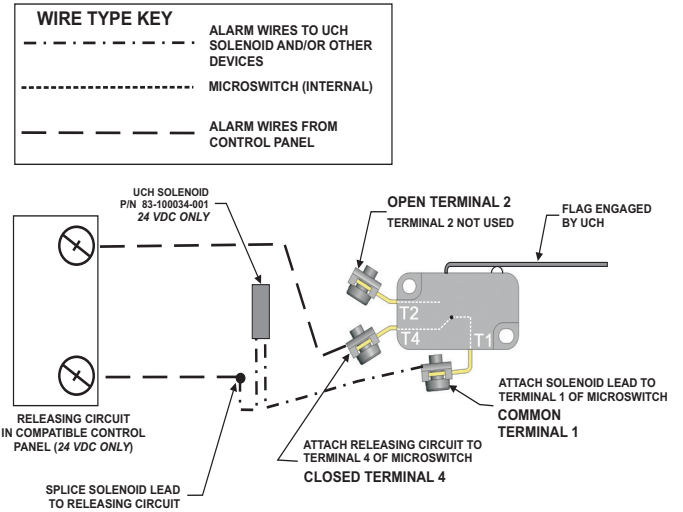

Figure 6. Solenoid, P/N 83-100034-001



SWITCH POSITION WHEN UCH FLAG/CAM IS IN SET POSITION

Figure 7. Release Wiring with Terminal Type Microswitch

Note: Where electric detection and/or actuation is provided, supervision shall be provided in accordance with NFPA 72, National Fire Alarm and Signaling Code. Alarms and indicators, along with a supervised power source, shall be provided in accordance with NFPA 72. Electrical wiring and equipment shall be provided in accordance with NFPA 70, National Electric Code. All installations are subject to the approval of the Authority Having Jurisdiction (AHJ).

KEEPER PIN, P/N 60-9197108-000

The Keeper Pin (P/N 60-9197108-000) is used to prevent actuation while installing the system.



Figure 8. Keeper Pin, P/N 60-9197108-000

Distribuidor Certificado en Panamá
 ABRASIL CO INC
 Vía Ricardo J. A. Edif. Tuira #-4
 Tel: 507-260-9061 // 236-5644
 abrasil@cwpanama.net

ORDERING INFORMATION

Description	Part Number
Universal Control Head includes: (1) 87-120042-001 System Valve Actuator (1) 87-120043-001 System Nitrogen Cartridge (1) 87-120044-001 Test Cartridge (1) 87-120058-001 EMT Connector Kit (1) 87-120039-001 Microswitch Kit (1) 87-120039-501 Microswitch Kit	60-120099-002
System Valve Actuator	87-120042-001
System Nitrogen Cartridge	87-120043-001
Test Cartridge	87-120044-001
High Pressure Hose for Cylinder Mount	87-120045-001
EMT Connector Kit	87-120058-001
Solenoid Electric Actuator Kit	83-100034-001
Microswitch Kit (SPDT), Solid Color Leads	87-120039-001
Microswitch Kit (SPDT), Striped Color Leads	87-120039-501
Terminal Type Microswitch Kit (SPDT)	87-120047-001

REFERENCE INFORMATION

- Range Guard Systems designed and installed according to manual P/N 60-9127100-000.
- Industry Guard Systems designed and installed according to manual P/N 60-900000-001.
- Vehicle Spray Booth Systems designed and installed according to manual P/N 60-900007-001.

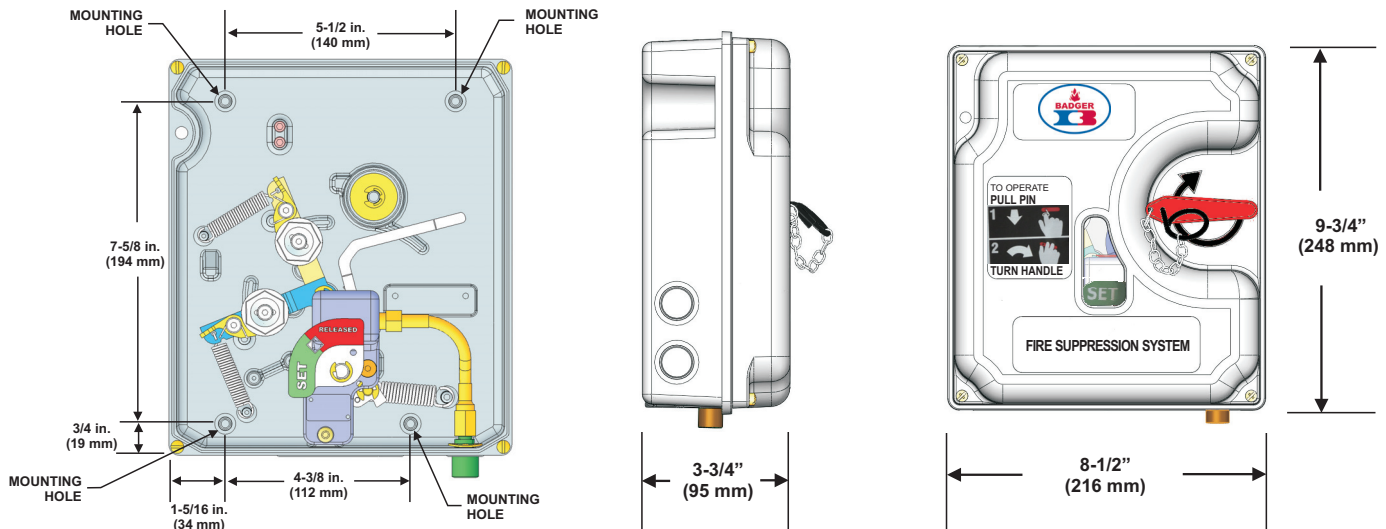

Figure 9. Universal Control Head Dimensions

Kidde and Range Guard are registered trademarks of Kidde-Fenwal, Inc.
 AEGIS, and ARIES are trademarks of Kidde-Fenwal, Inc.
 Badger is a registered trademark of Badger Fire Protection.
 Industry Guard is a trademark of Badger Fire Protection.



B-87-027 Rev AE

This literature is provided for informational purposes only. BADGER FIRE PROTECTION assumes no responsibility for the product's suitability for a particular application. The product must be properly applied to work correctly.

© 2013 Badger Fire Protection

Badger Fire Protection
 944 Glenwood Station Lane
 Suite 303
 Charlottesville, VA 22901
 Ph: (434) 964-3200
 Toll Free: (800) 446-3857
www.badgerfire.com

Kidde Canada, Inc.
 340 Four Valley Drive
 Vaughan, Ontario L4K 5Z1
 Ph: (905) 695-6060
 Toll Free: (800) 565-1976
www.kiddecanada.com